

# Sample Cylinders. Simplified.

The safe and simple alternative  
to Sample Panels and Closed  
Loop Systems.

BIAR   
Sampling Systems

## SAMPLING SYSTEM FOR HF ALKYLATION

MLB-SO Sample Valve

Columbia-LY-SO Sample Cylinder

# UOP OR CONOCOPHILLIPS ALKYLATION PROCESS

Whether it is UOP or Phillips Alkylation process, optimization of the net consumption of HF acid is critical from a profitability as well as from a product quality point of view.

**Sampling** allows to monitor the concentration of HF, acid-soluble oils (ASO) and water. Due to the extremely hazardous nature of HF, it is common for refineries to find this process challenging.

The typical location of HF Acid sampling is at the bottom of the Settler, on the way back to the reactor.

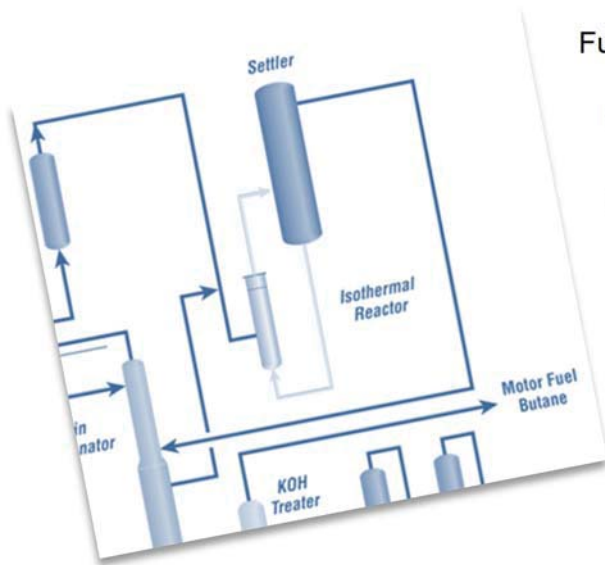

Fundamental principles of Sampling Hazardous Chemicals:

1. The sample must be **REPRESENTATIVE**
2. Sampling must be **SAFE**

## SIMPLER IS BETTER

- Easy to learn & use
- Maintenance free
- No quick-connect & flexible hose

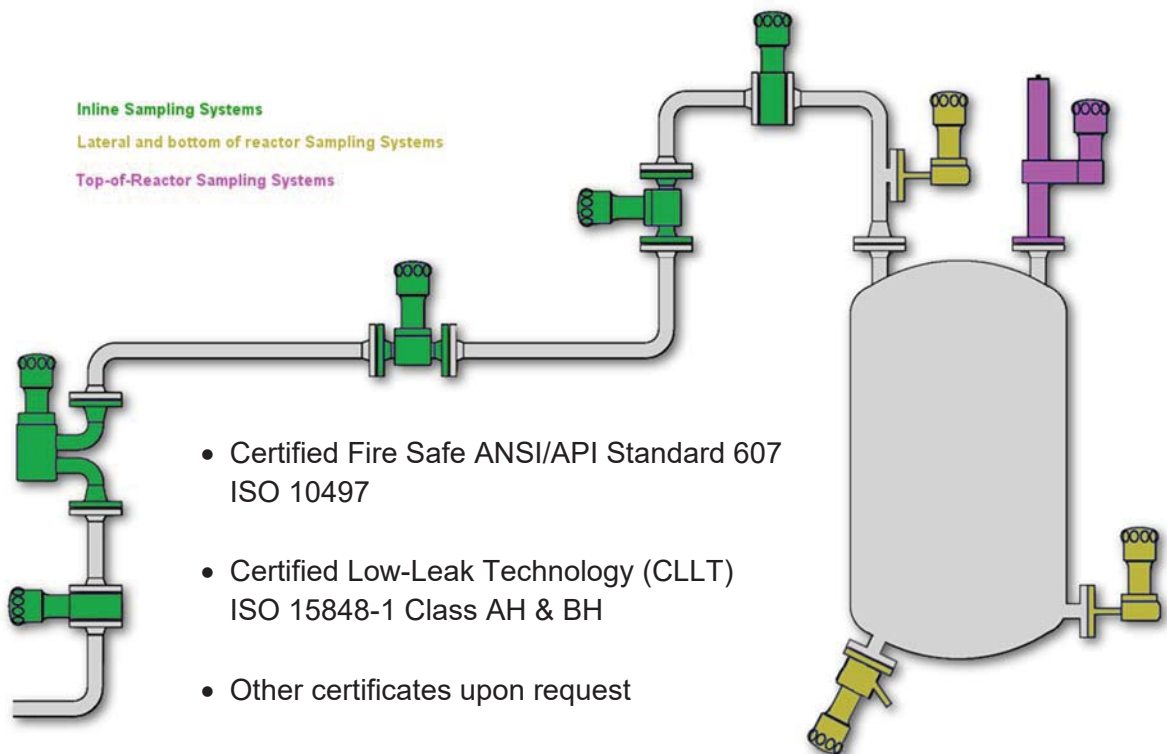

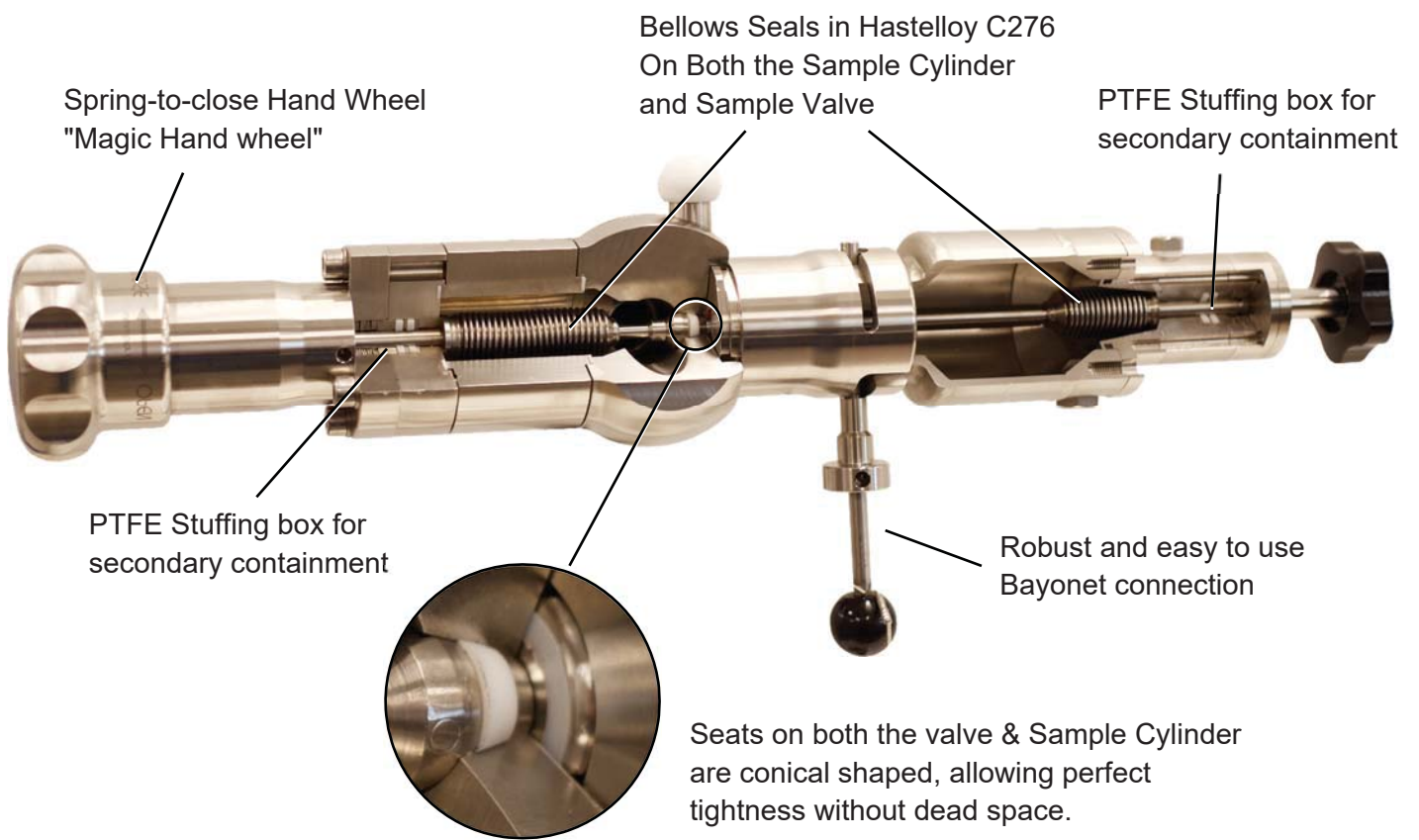

## SIMPLE & SAFE CONCEPT

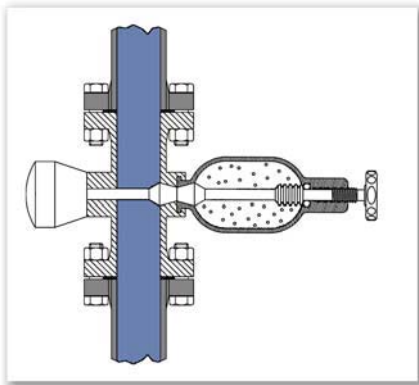

The Sample Cylinder has been cleaned / dried at the lab. When ready to use, simply connect it to the Sample Valve.

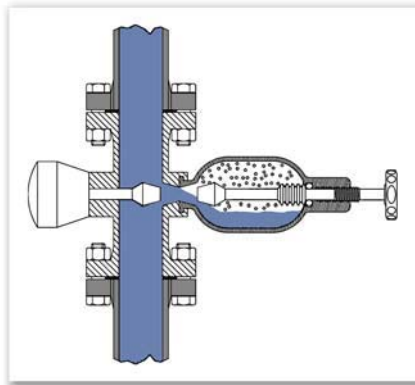

Open both the Sample Cylinder and the Sample Valve to collect a Representative Sample.

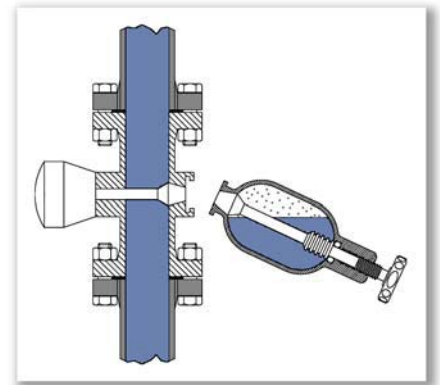

Once the Sample is grabbed, close both the Sample Valve and the Sample Cylinder. Disconnect the Cylinder from the Valve.

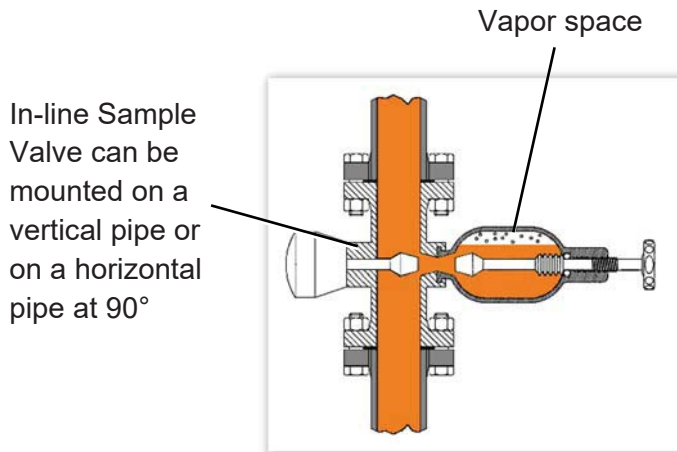

When used horizontally, BIAR sample containers COLUMBIA-LY create a vapor space that is necessary for volumetric expansion of the liquid.

### Use

Outage is the vapor space in the cylinder expressed as a percentage of the total volume of the cylinder.

$$\% \text{ outage} = (\text{vapor space} / \text{total volume}) \times 100$$

BIAR Sample Cylinders provide 40% outage as standard.

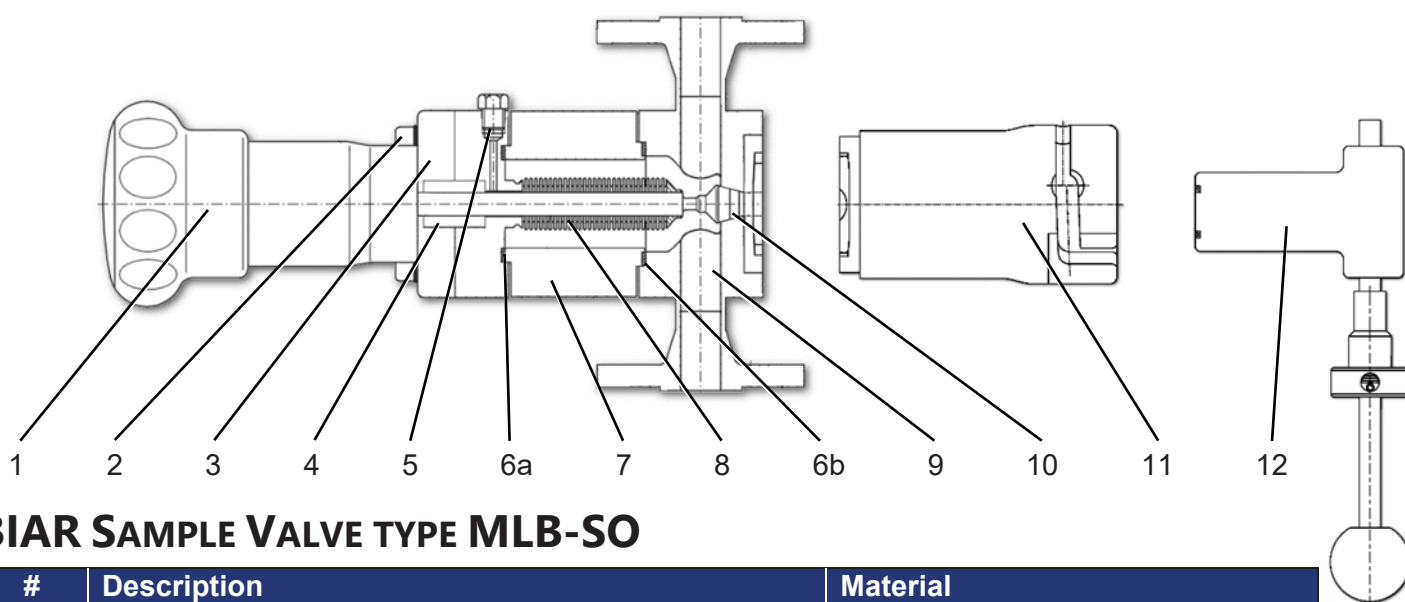

## BIAR SAMPLE VALVE TYPE MLB-SO

#	Description	Material
1	Spring-to-close hand wheel (AKA Magic Hand Wheel)	316SS
2	Socket head cap screw & Spring washer	316SS & 301SS
3	Stuffing box cover	316SS
4	Secondary stuffing box	PTFE / 316SS / 301SS / Monel 400
5	Plug for leak detection port	Monel 400
6a+6b	Body gaskets	PTFE
7	Spacer	Monel 400
8	Stem with bellows-type seal	Hastelloy C276
9	Valve body	Monel 400
10	Seat gasket	PTFE
11	Bayonet connection	Monel 400
12	Safety plug (secondary containment)	Monel 400 / PTFE / 304SS

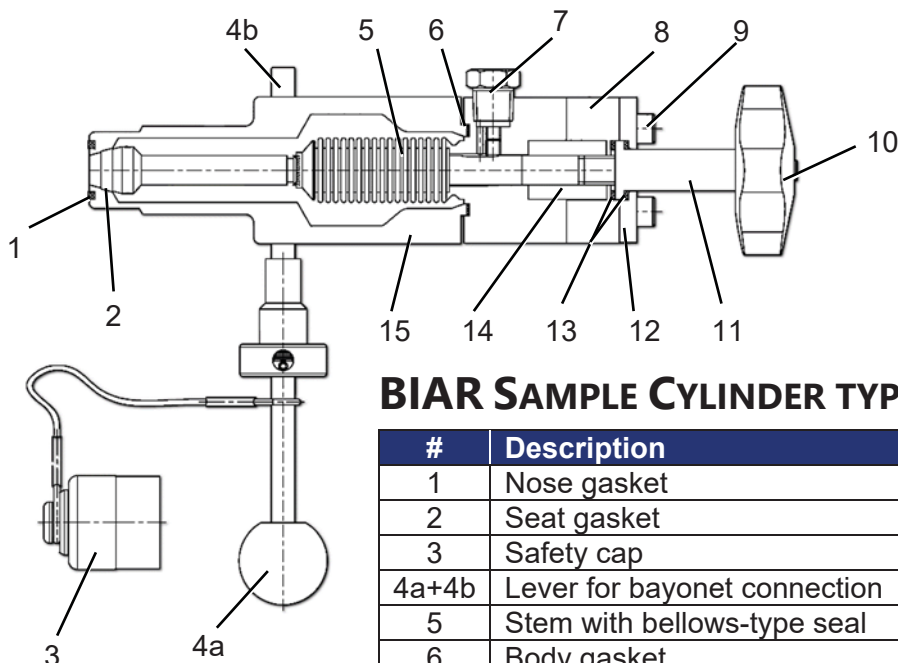

## BIAR SAMPLE CYLINDER TYPE COLUMBIA-LY-SO

#	Description	Material
1	Nose gasket	PTFE
2	Seat gasket	PTFE
3	Safety cap	Hastelloy C276 / PTFE
4a+4b	Lever for bayonet connection	304SS
5	Stem with bellows-type seal	Hastelloy C276
6	Body gasket	PTFE
7	Plug for leak detection port	Hastelloy C276
8	Stuffing box cover	Hastelloy C276
9	Socket head cap screw	316SS
10	Hand wheel	Plastic
11	Driving nut	Hastelloy C276
12	Cover for hand wheel	Hastelloy C276
13	Washer	Carbon loaded pTFE
14	Secondary stuffing box	PTFE / Hastelloy C276
15	Cylinder nose	Hastelloy C276

# EASY AND SAFE EXTRACTION OF THE SAMPLE FOR ANALYSIS

The adjustable height Laboratory Stand is used to depressurize the Sample Cylinder and transfer HF to Gas Chromatography (GC) Systems and Karl Fischer titration.

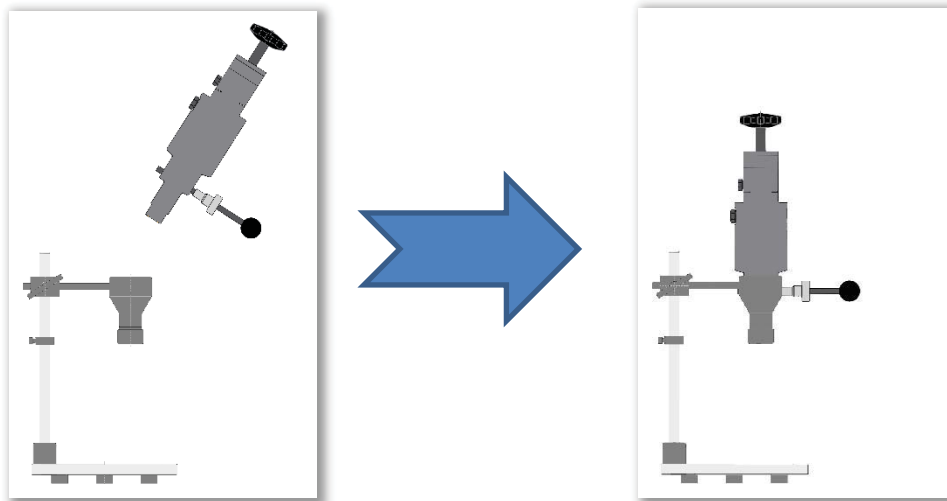

Example of how the Sample Cylinder is used at a the lab under the hood in a refinery

### Advantages of BIAR Sampling Systems

- Directly representative Sample, the first time, Every time
- Simple: minimum number of steps required
- Safe, robust design
- "Failsafe" spring-to-close
- No flushing/purging required
- Minimum number of potential leak points
- Suitable for toxic / lethal Chemicals

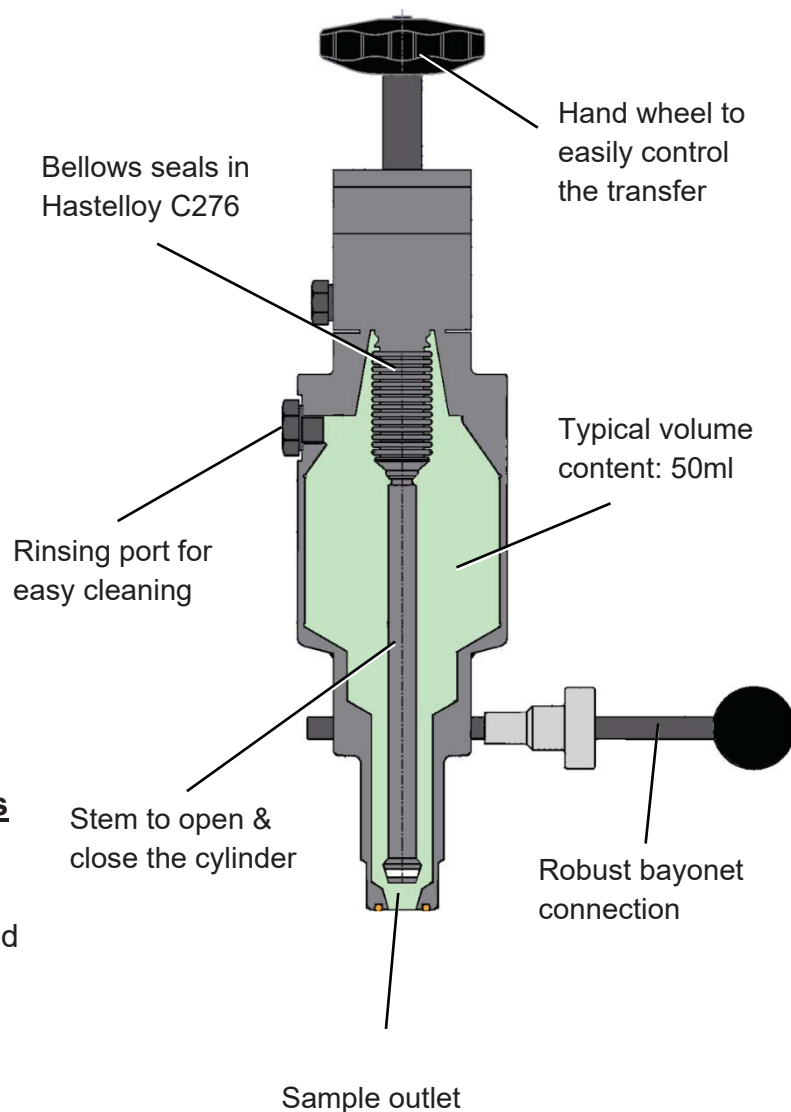

# PROVEN TECHNOLOGY FOR SAFER PROCESS

## BIAR SAMPLING SYSTEMS

VS

## SAMPLE PANELS & CLOSED LOOP SYSTEMS

- ✓ Simple
- ✓ Minimum number of steps required
- ✓ Only two valves to operate
- ✓ Limited potential leak points
- ✓ Safe, robust design
- ✓ Failsafe spring-to-close
- ✓ Installs directly on pipeline
- ✓ Directly representative Sample, the first time, every time

- ✗ Complicated
- ✗ Numerous steps required
- ✗ Several valves to operate
- ✗ Many potential leak points
- ✗ Light / fragile fittings
- ✗ Small tubing needed
- ✗ Recycling / flushing / purging



HF Alkylation Equipment  
17546 N. Airline Highway  
Prairieville, LA 70769

[info@hfalkylationequipment.com](mailto:info@hfalkylationequipment.com)  
Phone: 225-442-1000



BIAR Sampling Systems  
2506 S. Philippe Ave.  
Gonzales, LA 70737

[contact@biar.us](mailto:contact@biar.us)  
Phone: 225-647-4300

*biar.us*

## SAMPLING SYSTEM FOR HF ALKYLATION